

LINEARPOTI

Cylindrical displacement transducer with magnetic drag for contactless measurement



**Series
LMI & LME**

- *Cursor type for contactless ring magnet*
- *Suitable for harsh environment applications (IP68)*
- *Sensing element separate with case*
- *Up to 400 Bar for hydraulic cylinder*
- *Speed displacement 5 m/s*
- *Linearity 0,05%*
- *Infinite resolution*
- *Working temperature -30...+100°C*
- *Life time > 25x10⁶ Meter or 100x10⁶ operations*

Technical Data

Range	50 - 1,000 mm	Max. application voltage	see table
Displacement speed	< 5 m/s	Max. cursor current in case of bad performances	< 0,1 μ A
Cursor dragging force	<0,5 N	Temp. Coeff. of the resistance	-200 \pm 200 ppm/ $^{\circ}$ C
max. acceleration	< 10m/s ² displacement	Actual temperature coefficient of the output voltage	<1,5 ppm/ $^{\circ}$ C
DIN vibration IEC68T2-27	12g, 10...2000 Hz	Electrical isolation	>100M Ω at 500V, 1 bar, 2s
Shock test DIN IEC68T2-27	50g, 11ms. Single shock	Dielectric strength	< 100 μ A at 500V~, 50Hz, 2s, 1bar
Linearity	see table	Working temperature	-30...+100 $^{\circ}$ C
Resolution	infinite	Storage temperature	-50...+120 $^{\circ}$ C
Tolerance on resistance	\pm 20%	Housing material	Aluminium, high grade steel (LMI)
Recommended cursor current	< 1 μ A	Mounting	flange/terminal plate
Max. permitted dissipation	<10 mA	Displacement sensitivity (no hysteresis)	0.05 to 0.1 mm
Dissipation at 40$^{\circ}$C (0W at 120$^{\circ}$C)	see table		
Protection LME 12	IP 67		
Protection LMI 12	IP 68, max.pressure 250 bar, 400 per peak		

Electrical and Mechanical Data

Model		50	100	150	200	250	300	350	400	450	500	550	600	650	700	750	800	850	900	950	1000	
Useful electrical stroke	mm	Model																				
Theoretical electrical stroke (C.E.T.)	mm	E.N.W. + 1																				
Resistance (C.E.T.)	kOhm	5					10					20										
Independent linearity (within C.E.U.)	\pm %	0,1		0,05																		
Dissipation at 40 $^{\circ}$ C (0 W at 120 $^{\circ}$ C)	W	1	2	3																		
Max. application voltage	V	40		60																		
Mechanical stroke (C.M.)	mm	E.N.W. + 5																				
Case length (A) LMI 12	mm	E.N.W. + 94																				
Case length (A) LME 12	mm	E.N.W. +62																				

Electrical Connections

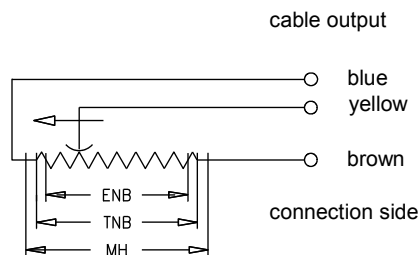

Tracking Error

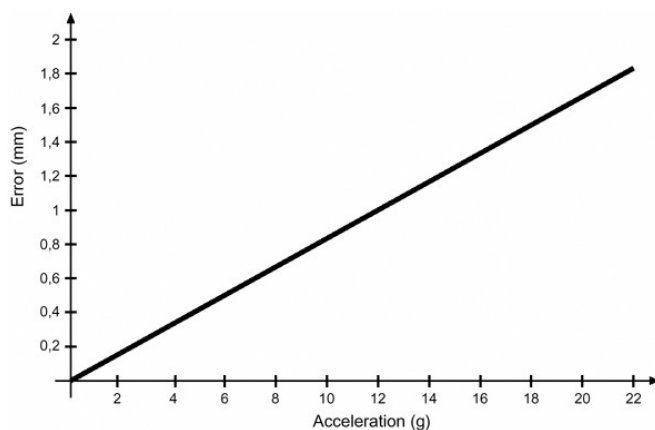

Dimensions and Electrical Data

LME 12

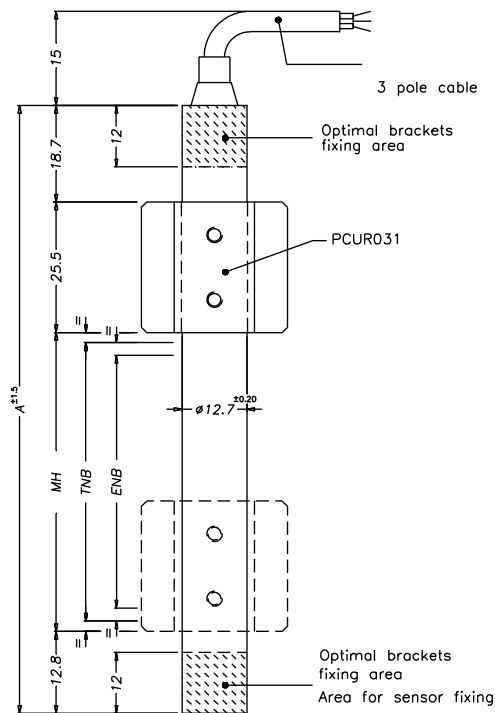

LMI 12

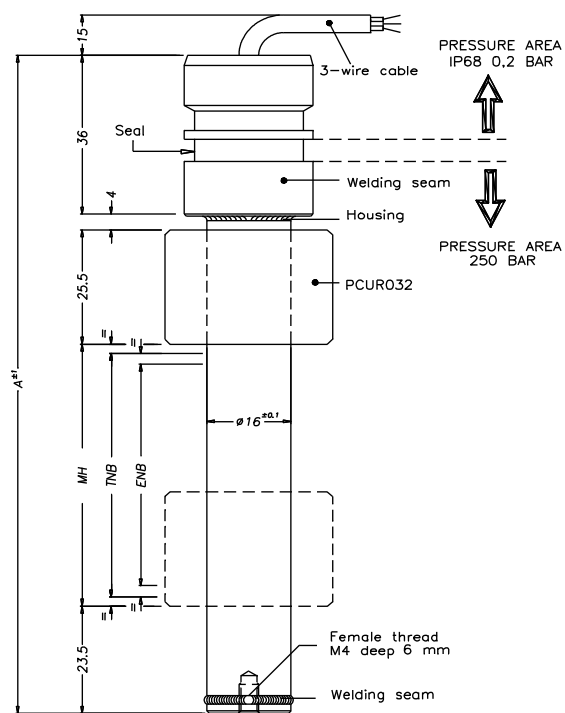

Assembly indication:

After installation of the sensor and putting on the magnet on the sensor, the unique magnet must be pushed entirely on the

sensor (up to flange / cable connection) to link the transmitter element in the sensor with the magnet.

PCUR031 Cursor

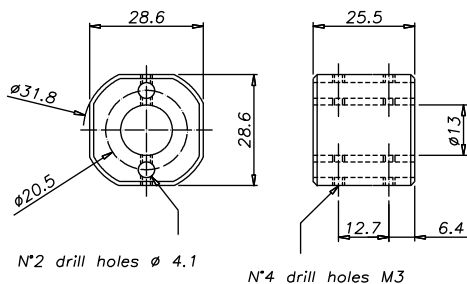

PCUR032 Cursor

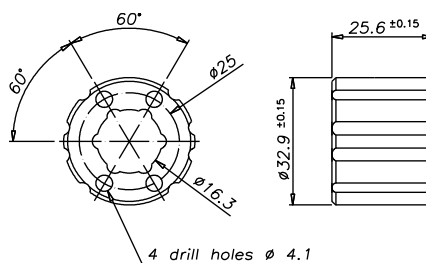

STA001 Brackets

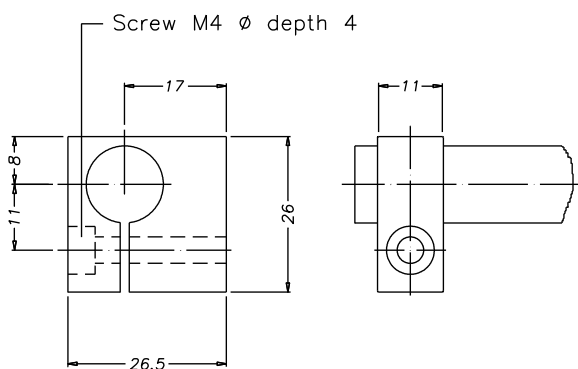

Case dimension

